

DESIGN AND CONSTRUCTION OF A REMOTELY CONTROLLED VEHICLE ANTI-THEFT SYSTEM VIA GSM NETWORK

K.S. Alli (1), C. Ijeh-Ogboi (2) and S.L. Gbadamosi (3)

Abstract- Abstract—Remotely controlled vehicle anti-theft system via GSM network is a system that explores the GSM network in order to produce a reliable and efficient vehicle security system. However, the design project can be viewed from two perspectives viz the hardware consideration and the software consideration. Minicom which is a terminal emulation program on Linux was utilized for the configuration of the Modem used in this project work due to its inherent advantages. Communication between the user and the vehicle sub-system is via sms (Short Messaging Service) messaging. SMS commands are sent to the GSM/GPRS Modem Module. The GSM/GPRS interpretes the message and performs necessary control actions. Also, sms messages are sent from the GSM/GPRS Modem Module to the user's mobile phone whenever an alarm situation occurs. However, a toy car was used as a prototype display of this project work and prototype car was immobilized and demobilized from a mobile phone via SMS

Keywords— GSM/GPRS Modem Module, Remote Access Link, AT-Commands, Vehicle Subsystem.

i. K.S. Alli,(1) Ph.D Student at the Department of Electronic and Electrical Engineering, Obafemi Awolowo University, Ile-Ife, Nigeria. Email: allikolapo@gmail.com

ii. C. Ijeh-Ogboi (2) is with the Department of Computer Engineering, Afe Babalola University, Ado-Ekiti, Nigeria. Email: chrislab2008@abuad.edu.ng

iii. S.L. Gbadamosi (3) is with the Department of Electronic and Electrical Engineering, Afe Babalola University, Ado-Ekiti, Nigeria. gbadamosiadeolu@gmail.com

1. INTRODUCTION

The rate of increase in car theft in this part of the world has reached an alarming rate. In the rave of this development, engineers in this country have been performing researches aimed at providing a lasting solution to this endemic act. This project is attempt to proffer a lasting solution thought of exploring the GSM technology coupled with some digital control techniques as possible remedy. The project is divided into two subsystems: the remote access link and the vehicle subsystems. The system can be controlled from anywhere in the world once there is GSM coverage. Previous works have been done involving tracking of vehicle location via the internet. The use of the internet was only restricted to places where there is internet access facilities. However, this system was only explored to track down the exact location of a vehicle but not to demobilize the vehicle from a distant place. Instead of the embedded web server used by previous designs to gain access through the internet, this present design employs the use of a GSM/GPRS modem (Modulator and Demodulator) module to gain access to the vehicle subsystems. The importance of this project cannot be over emphasized since it helps to reduce the rate of vehicle theft with our society. For instance, when there is an intruder into the vehicle, the system will immediately and automatically sent out emergency warning signals to the user's phone, reporting the status of the car and preventing the car from being stolen.

In case of hijacking, the driver can leave the car safely, and then he/she could use any phone to send out some commands and remotely cut off power/gasoline supply, so as to stop the car from running and get back the car easily. In such case, the vehicle snatcher will not be in a position to harm the vehicle owner. Time snapshot of the driver is also taken using DM642 media processor and displayed on the LCD screen with available profile information. The smart car can also be remotely locked or unlocked using GSM modem. Another feature of navigation and tracking of car using GPS module is also included in the system. The system takes latitude and longitude positions.

A. The aims and objectives of this systems are as follows.

The goals of this research include the following:

- To design and construct a remotely controlled vehicle anti-theft system via GSM network;
- To be able to access the vehicle subsystems from a remote/distant location where there is a GSM coverage;
- To initiate some control actions on the vehicle from a mobile phone;
- To monitor the state or condition of the vehicle after it has been stolen;
- To give the vehicle sub-units some level of intelligence.

2. LITERATURE REVIEW

Car security system has been very popular in recent times and widely used in most cars and automobiles owned by companies, business organization and even by some private individuals who can afford the cost. The most common automobile security system has been the manually operated demobilizer. Few of the many automobile theft-prevention system allow a vehicle to start and temporarily run before disabling a critical component, such as the fuel or ignition system. This type of shut down sequence is not very confusing and the system could possibly be overcome by the thief [16]. Also, [1] has developed a security system titled: "Design and Construction of a home automation via domestic power line and GSM network which can be used to monitor home appliances in an automated form via the GSM network. [14] have developed embedded system design to control automobile peripherals automatically through voice recognition system. The profile of the authorize user was configured and saved in the system which operates specific settings for the user. Whenever the user wishes to drive the car, system will initiate the personal settings by identifying the users voice which includes the side and rear mirrors setting and seat adjustments.

The use of DM642 media processor allows the real time snapshot of the driver to be taken and displayed on the LCD screen with available profile report. The remotely operation of the smart car locked or unlocked was also performed using GSM modem. Some another features such as navigation and tracking of car using GPS module was also incorporated into the system. The latitude and longitude positions were also taken by the system from GPS and sends to the PC using GSM modem. The car real time location was also displayed on the map on PC.

Also [22] have presented Short Message System (SMS) based home security system equipped with motion sensor, smoke detector, temperature sensor, humidity sensor and light sensors. A microprocessor PIC 18F4520 controlled the sensors through the SMS being password. The home security operation has been tested on Vodafone- Fiji network for emergency and feedback responses were obtained for 25 samples. The GSM experiment showed that it takes about 8-10s delay for the security system to reply the relevant civil authorities and occupant in case of emergency. The occupant takes about 18-22s to energize and monitor lights and appliances and then get feedback from home due the network traffic. [13] have presented the " Design and Development of Activation and Controlling Of Home Automation System VIA SMS (Short Messaging Service) through Microcontroller" which was used to control home appliances remotely when the user is absent from the place. The system is SMS based and user uses wireless technology (GSM). The

system uses GSM technology thus, provides universal access to the system for automated appliance control. GSM (Global Systems for Mobile Communication) is highly used due its simplicity in both transmitter and receiver design, can operate at 900 or 1800MHZ band, faster, more reliable and globally network.

[7] have presented a theft warning system that simulates problems in motor vehicles. This work illustrated, in the process of starting the engine, this system permits normal engine operation for a random time duration which it can be deactivated. The device functions well in conjunction with any alarm device but not an alarm system. Whenever an unauthorized use is identified, a unique controlling signal with random timing variations digital controller randomly is generated that communicates to the remote receiving subsystem interface units. These units are connected in series with vital vehicle subsystem components in order to interfere with typical subsystem component operation, thus inducing the illusion of an actual vehicle severe problem to inhibit vehicle safety. A unique operation of the system was implemented by locating disabling receivers on any variety of vital vehicle subsystem, presenting thieves with multiple unknowns specific to each vehicle. Because of this, there is no opportunity for a pattern to develop, and thus an unauthorized operator can be recognized by this device. This system constitutes several components coupled with vehicle subsystems. The GSM/GPRS modem module is the main central controller system which incorporates the capability of a microcontroller. The entire system is monitored by the module, communicating with one or more remote disabling receivers

(GSM phone), which acts as an interface circuitry between the controller and the subsystem of the motor vehicle. The generation of random control information signals is performed by the onboard controller. Various methods can be used to generate the random control information signals, which include receiving of a radio frequency, or programming a microcontroller, using digital logic components, to allow a random control information signal [7]. The system functionality is based on the ignition keyswitch and anti-hijacking output, in respect to an input circuit. The battery to the coil ignition system of the vehicle is connected simply to the keyswitch input. [18] have developed a security module for the car appliances to avoid stealing and illegal use on other cars. An open structure which includes authentication and encryption by embed a security module in each to protect car appliances was proposed. The identification of components which deals with relevant procedures were also presented in this work. This work was expected to create new business opportunity to the automotive and technology industry. [21] have also presented Vehicle Tracking System aims to determine the location of a vehicle using different methods like GPS and GSM operating systems through satellites and ground based stations. Information updates about vehicle like location details, speed, distance traveled etc can be assessed on a Google map via Internet with the help of Application Program Interfaces (APIs). This system is responsible for tracking of the registered vehicles at any specific period of time and is popularly becoming a theft prevention and retrieval device. The vehicle sends an SMS containing the GPS coordinates to the user by the tracking system installed in the vehicle, which he tracks the vehicle on Google Earth. The SMS can be forwarded by the user containing the GPS coordinates to his close friends and relatives if he wishes to, so that they can also track the vehicle using Google Earth. At the Department of Computer Science and Engineering,

[12] have studied the use of Biometric Approach for Vehicle Security System Using Fingerprint Recognition. In all the areas, an embedded computing technology is used. A competent automotive security system has been implemented using embedded system along with Global System for Mobile (GSM) and Fingerprint Recognition. Literature survey in this work has illustrated vehicle security system using person identification techniques. The survey mainly raised emphasizes on

major approaches for automatic person identification, such as fingerprint recognition and various existing vehicle security system. The security system can be implemented using Microcontroller.

An efficient automotive security system has been implemented by [15] for anti-theft using an embedded system occupied with a Global Positioning System (GPS) and a Global System of Mobile (GSM). In this work, the client communicates through this system with vehicles and the vehicles current locations and status are determined using Google Earth. The position of targeted vehicles is tracked by the user on Google Earth. By using GPS locator, the target current location is determined and sent, alongside with various parameters received by vehicles data port, via Short Message Service (SMS) through GSM networks to a GSM modem which is connected to PC or laptop. Discrete Kalman filter is used in this work to correct GPS coordinates. In order to secure the vehicle, the user in a group of users can turn off many vehicle of the fleet if any intruders is noticed to run it by blocking the gas feeding line. This system is considered safe and effective to report emergency situations such as crash reporting or engine failure.

[2] have presented a car security system that based on short message service for its activation and de-activation. The use of Sony Ericsson GSM modem (GM47) and microcontroller

ATtiny 2113 played a vital role in realization of the design. The GSM based wireless communication has provided the connectivity of the systems' operation, to offer a global, practical and cost-effective solution for wide-area coverage monitoring. The device during testing was able to execute command sent via text messages from mobile phone. [20] have presented a reviewed work on "Real time Car Antitheft System with Accident Detection using AVR Microcontroller". The use of AVR microcontroller has prevented the security system for cars from theft actions. This has also added various images to database whenever any person enters into car through the help of face recognition system, it then contrast image of that person with the existing images stored into the database and check for authentication whether the person is an authorized user before granting access into the car system and if not an authorized user, then the security system then block the car access and the car owner will be notified by Multimedia Message Services (MMS) about the unauthorized access via the use of GSM modem. Also, password authentication can also be provided by the security system whereby if car owner want to provide emergency access to some user whose image does not need to be recognized, but still it gets the access into the car system. In addition, this security system can also function as accident detection which notifies to the users. In that case, nearest police station or hospital will be contacted via SMS. Work has also been performed on the use of wireless home security system by using mobile phone presented by [17]. The work was to investigate a cost effective solution which can provide remotely control of the home appliances

and enables home protection against intrusion in the absence of owner of the home. The system makes use of modern wireless communication like Bluetooth, Infrared and Wi-Fi access for security and automated appliance control operation.

Nowadays, home security has become a serious issue where crime rate is increasing and everybody wants to ensure proper prevention against intrusion. The operation of system on different wireless communications and newest 3 of 10 mobiles uses for security purpose. The remote controlling of appliances is involved in the proposed system whereby the intrusion detection, system security and auto-configuration adjust the system settings on running hardware support check. [11] have evaluated experimental security of a modern automobile. This paper shows experimental evaluation issues on a modern automobile and demonstrated the instability of the underlying system structure. It was also carried out on an attacker who is able to penetrate virtually any Electronic Control Unit (ECU) can influence this ability to completely avoid some safety-critical systems. In both the lab and road tests experiments conducted, the ability to oppositionally control a broad range of

automotive functions and completely ignore driver input including brakes disabling, selectively braking individual wheels on demand, stopping the engine, and so on, were demonstrated. The obtained results showed that it is possible to introduce elementary network security protections into the car.

Advanced Car Security System Using GSM has been proposed by [8]. This system makes use of the GSM mobile communication networks to send out alarm warning and control instruction. A short message services (SMS) protocol available in the mobile phone is used to establish the control and communication between the user and the proposed system.

Whenever the car door is illegally opened by unauthorized person or the car is vibrated, an alarm system will be triggered and the security system sends an automatic SMS message to the owners mobile phone immediately. However, this system will ensure the user could easily protect and control their car anywhere at any time. The proposed system is divided into two parts: hardware and software parts. The hardware components compare of the vibration sensors, a PIC microcontroller, a GSM modem, LCD and buzzer while the software part involves a program controller interface. The programming language used to configure this control system is PIC MikroC programming language. The control system is implemented using PIC 16F877A microcontroller and AT COMMAND. [23] has proposed the use of MMS Based Car Security System for solving issue. This system integrated monitoring and tracking system. SMS and MMS are sent to the owner to initiate fast response most especially when the car is close by.

This project focuses on SMS and MMS technology. Whenever intrusion is detected, the SMS and the picture of the intruder are first sent to main user via local GSM/GPRS service provider to user (and/or) police mail ID. The results obtained from the implementation and testing indicated the success in sending MMS to owner within 30 seconds by the prototype.

The time taken to receive the SMS and MMS by the owner and police are suitable to take action against intruder. Control commands are also sent to the module by the User while configuring module for master. Only master user can make changes in the module. The use of Microcontroller for Anti-theft Security System via GSM Networks with Text Message as Feedback was proposed by [9] which makes use of an embedded system design with Dual Tone Multi Frequency (DTMF) and a GSM for monitoring and protect a vehicle. This system protects the vehicle against theft action. Whenever the security system is activated as a result of intrusion, it automatically disconnects the car ignition key supply from the car battery and demobilizes the vehicle while making it impossible for anybody neither starts the car engine nor moves the vehicle. However, if a theft tries to open through the car doors or boot, SMS is sent to the car owner by the security system embedded inside the vehicle system and triggered an alarm system. This design project was prompted by the increasing rate at which packed cars are stolen especially in the authors' environment, while this design system has been able to secure packed cars and monitored the respective vehicle's location, provided there is GSM network coverage. From the survey conducted, it was observed that most existing car security system uses only alarm system but SMS are not sent to the vehicle owner neither demobilizing the car. The utilization of GSM network, SMS are sent to the vehicle owner through text message to his phone, and at the same time, some certain warning operations can be initiated and the car is demobilized from mobile phone by the vehicle owner.

An auto security anti-theft system with an Immobilizer system through the radio frequency identification (RFID) has been presented by [10] which characterizes low hacking rate while ensuring the safety supports of the passengers when the vehicle is hijacked. The active RFID technology has been used for the operation of the immobilizer system whereby three control circuits from the receiving unit which are in the vehicle, namely, ignition circuit, power control unit, and automatic gear changing system, enabling the vehicle speed is brought down to zero in a gradual

safe manner. The proposed anti-theft auto security system has been tested under various climate conditions and possible signal instability situations were used to test its reliability. This paper proposes a smart anti-theft car security system, which not only identifies thief but also controls the car.

[19] has proposed an embedded control system platform, face recognition system, GPS (Global Positioning System) and MMS (Multimedia Messaging Service) modules by using WLD (Weber Law Descriptor) as an anti-theft smart vehicle security system. The image used is divided into number of units, then WLD is obtained in different neighborhood and for each unit of an image, WLD histograms are obtained to reserve spatial information. The obtained WLD histograms from different units are concatenated which results in the final set of a face image. Comparison was made between the extracted feature set of face image and that of feature set of database image and real time user identification is presented. The image of an unauthorized person is sent to user via MMS module, if detected unauthorized entry and by sending the image user to the embedded system via MMS module, the embedded security system takes immediate action to stop the vehicle. Also, GPS module is used to track the exact location of vehicle and prevented vehicle from theft action.

A. GSM/GPRS (Global System for Mobile Telecommunication/ General Packet Radio Service)

The GSM/GPRS modem module is a device suitable for higher level applications suitable for machine-to-machine applications. The automated modes enable the unit to wake-up an I/O (Input and Output) change, time schedule or network prompt are automatically report I/O status by SMS. GSM or TCP/IP socket are connected over GPRS. This is ideal for stand alone application where there is no microcontroller. The GSM/GPRS modem module used in this project application supports analogue and digital I/O. These digital I/O lines are used to control various systems built in the vehicle for control purposes.

B. AUTOMATED MODE

This mode allows an automated operation to be performed in response to one or more wake-up events. Following the automated operation, the GSM/GPRS modem module may return to a power-down or remain awake enabling a local or remote processor to communicate with the device. This mode is used to monitor the state of some vehicle sub-system and report the status of the vehicle to appropriate quarters. In response to the wake events, an automated operation is invoked. This includes timers for managing low power operation, sending SMS messages with optional I/O and GPS status, autodialing over GSM/GPRS with optional TCP/IP protocols, streaming of I/O and GPS status.

III. DESIGN METHODOLOGY

The complete setup for the remotely controlled vehicle antitheft system via GSM network was designed and constructed in modules and then the system architecture and hardware architecture are depicted in Figure 1 and Figure 2 respectively. Data communication with the GSM/GPRS modem module was achieved through the communication (serial) port of a PC.

A terminal emulation program (HyperTerminal) was utilized on the PC with various windows operating systems. Several equivalent programs are also available such as the free Tera Term software but the HyperTerminal was used. Once, the terminal session is established, it is possible to communicate with the GSM/GPRS. To verify that the modem is properly connected, some "AT" commands were sent to the modem from the write window of HyperTerminal. The command response from the modem indicates ERROR, OK or other possible responses [3]. If the modem fails to communicate, the fault diagnostics routine can be referred to [4].

A. GSM/GPRS MODEM MODULE CONNECTION CONSIDERATION

The connector headers listed in Table II describes the functional units located on the modem module [6]. However, out of the list only CON 1, CON 2 and CON 4 are applicable to this project. The main communication takes place via CON 1. This connector hosts power, data lines and RESET. A version of the modem is which has CON 1 connector relocated to the bottom-side of the board: in this instance, the connector is

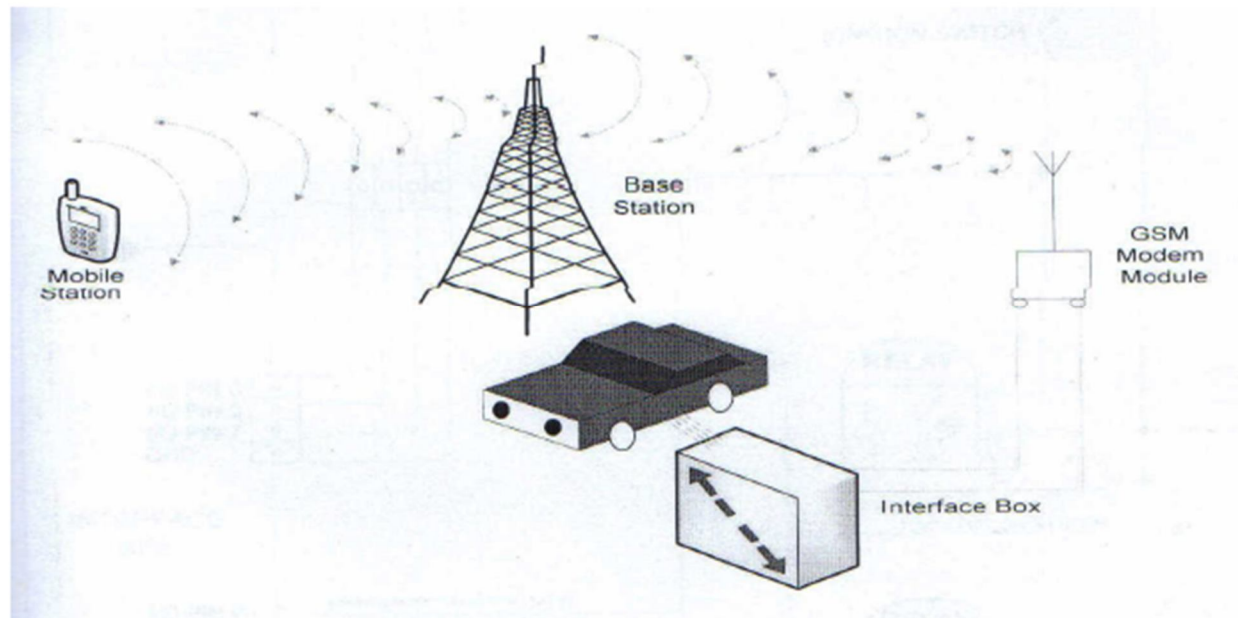

Fig. 1. Block Diagram of a Remotely Controlled Vehicle Anti-theft System via GSM Network termed CON 7. The GSM/GPRS modem module provides 8 digital I/O lines and four 10-bit ADC channels. The I/O and ADCs provides remote monitoring and can be used to invoke an automated action. Three I/O lines are used for the following tasks:

- Triggering of the vehicle demobilizer unit.
- Starting the Alarm
- Remote vehicle ignition monitoring.

B. HARDWARE INTERFACING VEHICLE SUB-SYSTEMS WITH GSM/GPRS MODEM MODULE

This section describes how various application units are interface with the GSM/GPRS modem. The GSM/GPRS modem however serves as the central controlling unit. This was made possible by the presence of I/O lines on the modem which eliminates the need for a microcontroller units.

C. VEHICLE DEMOBILIZER SUB-SYSTEM

An I/O line on the modem controls the vehicle demobilizer unit. This line energizes a relay which cuts of the battery to the coil ignition system of the vehicle i.e toy car used in this project. The circuit schematic for the section is as shown in Figure 4.

D. REMOTE IGNITION MONITORING SYSTEM

This section is made up of a unit that monitors the status of the vehicle ignition unit. In this case, an I/O line is configured as an input to the modem. The signal received at this I/O line is used to trigger the modem to wake up from a sleep mode. After which it sends an emergency warning signal by auto-dialing the user's mobile phone number. The interfacing diagram is as shown in Figure 5

E. Network & RTC (Real Time Clock-CON 4)

The GSM/GPRS modem is supplied with an on-board GREEN LED which indicates the network status. The Table I shows the LED indication together with the operational status.

IV. MODE OF OPERATION**REMOTE ACCESS LINK:**

This segment deals with the means by which the user gains access to the vehicle subsystems.

The link is via GSM network. A GSM Modem Module mounted inside the vehicle provides the facility to be able to communicate with the mobile station (mobile phone or any other GSM modem device). Various range of GSM/GPRS modem module exist with various range of operating frequency. Also, the GSM/GPRS modem module is configured to accept instructions only from specified mobile phone numbers. A simcard reader/slot contained in the board houses the SIM card used in this application. Once the users dials the number residing in the module SIM card, the GSM/GPRS modem module responds and connection is established between the access remote link and the vehicle sub-system. After this link has been established then necessary control and monitoring actions can be initiated on the mobile station (mobile phone) and these allow us to initiate necessary command programs (AT commands) and carry out the desired actions depending on the security status of the vehicle at that particular time.

The whole segment integrates various sub-systems for proper operations. These are; GSM Modem Module, Mobile station (mobile phone) and the base station. The system was designed so that text messages sent from a remote location using a

TABLE I
NETWORK STATUS INDICATION

LED Indication	Operational Status
Off	No power or in the OFF State.
Steady	Power on, not connected to a network.
Blinking	Power on, connected to a network

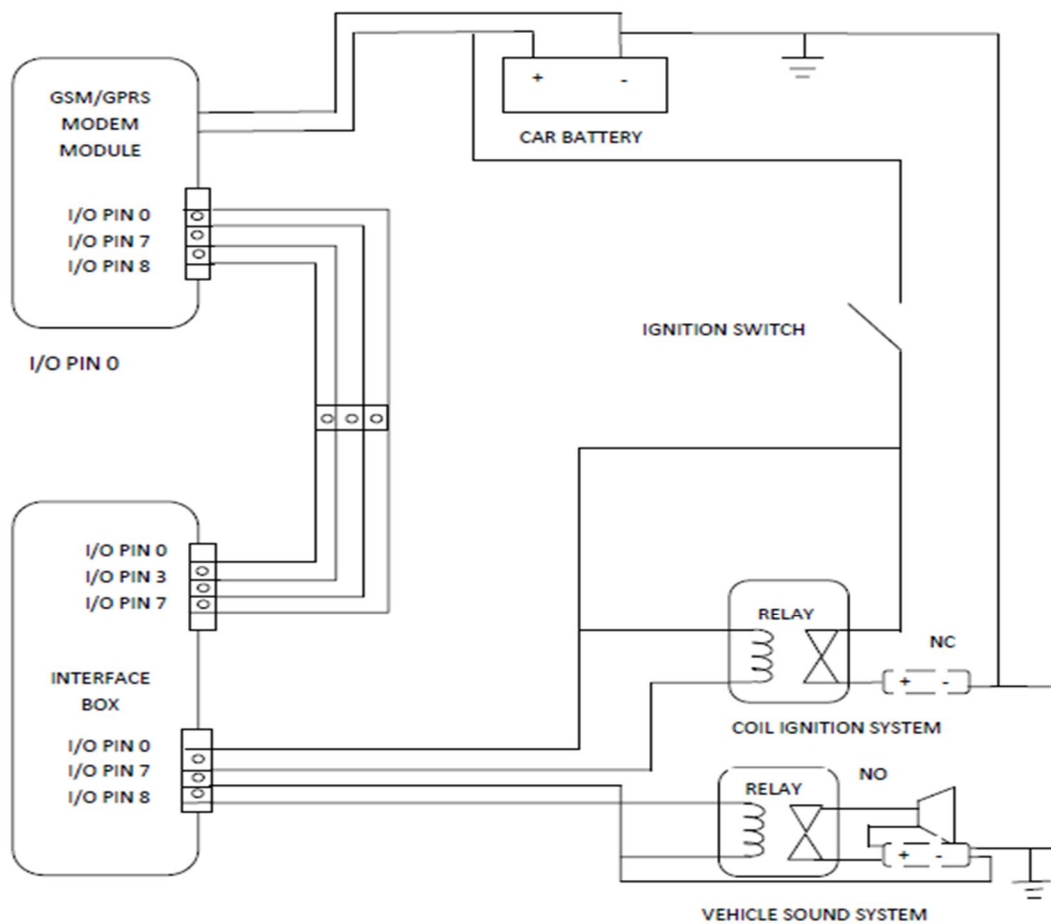

Fig. 2. Wiring Diagram of Vehicle Control Subsystem

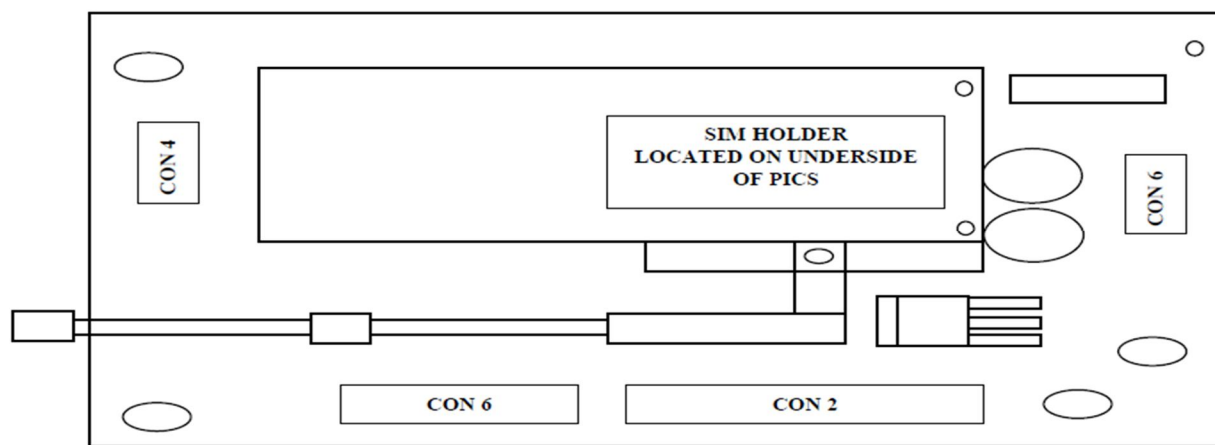

Fig. 3. GSM/GPRS Modem Connector Layout.

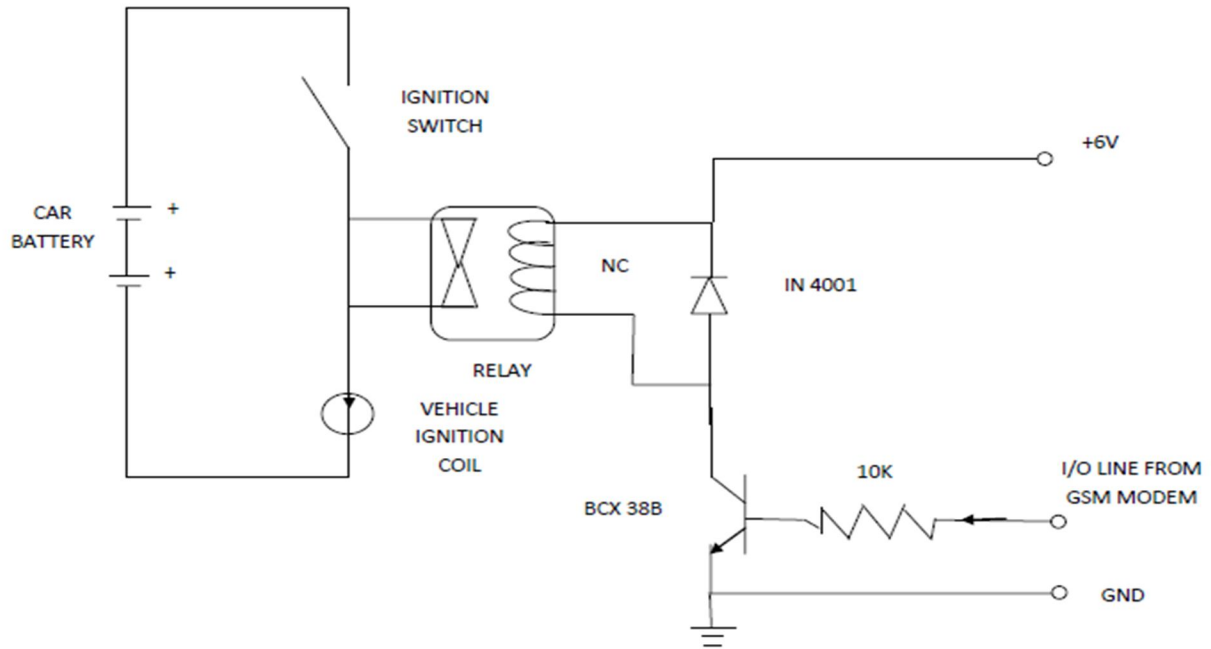

Fig. 4. Demobilizer Interfacing Circuit.

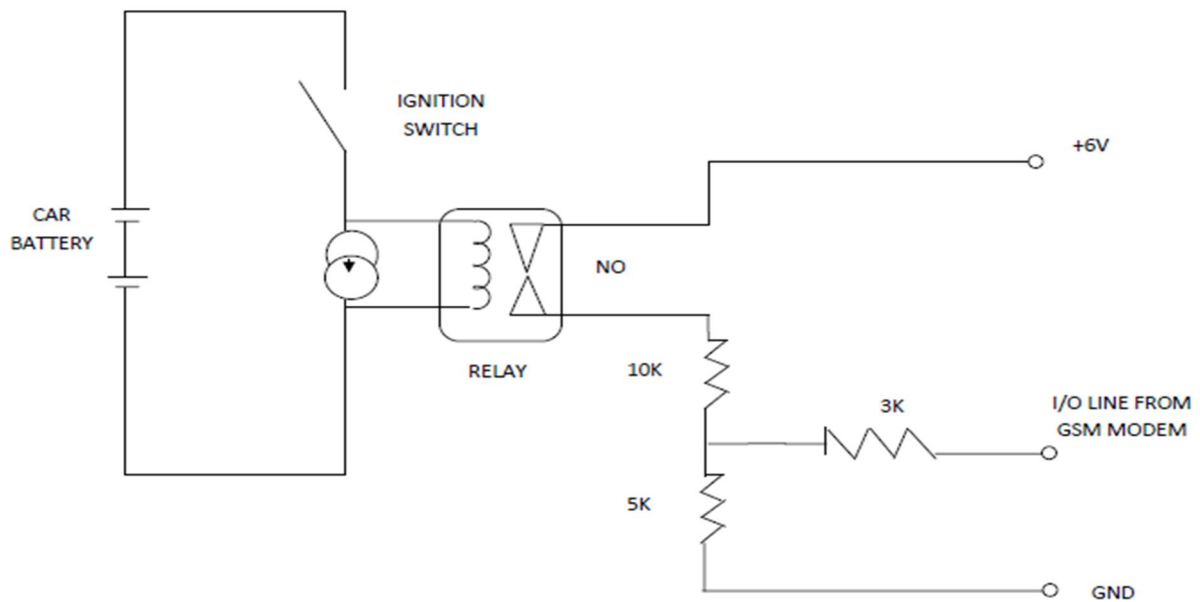

Fig. 5. Ignition Monitoring Interfacing Circuit.

TABLE II
GSM/GPRS MODEM MODULE CONNECTOR DESCRIPTION

Connector	Description
CON 1	Power and Host Serial Header (top side of PCB)
CON 2	I/O Header
CON 3	Interface Header (GPS serial header)
CON 4	Network Status and Real Time Clock (RTC)
CON 5	Audio Header
CON 6	Aux Power In
CON 7	Power and Host Serial Header (bottom side of PCB)

mobile phone are transmitted to the GSM modem which interprets the message and in turns encodes and performs the action specified in a command line via the communication I/O port.

A. GSM MODEM MODULE

Modem module GSM/GPRS integrated wireless modems provide a quick and easy way to insert GSM and GPRS functionality into systems and terminals. Available in dual band configurations, this modem constitutes a self-contained, fully integrated implementation of the GSM/GPRS Standard. It has an integrated SIM connector. The modem module has two logical functional ports; the hardware port and the software port (AT commands).

B. Hardware Consideration

The GSM modem module used is based on a dual band RF Module, which is it can operates on both frequency of 900MHZ and 1800MHZ with SMS (short message service) service. It has an integrated SIM socket which houses the SIM and operates on the baud rate of 9600 baud, on the 10-pin TTL (RS232 optional) serial host interface at the point of connection to other networks/computer peripherals.

C. Software Consideration (AT Commands)

The software used in programming the GSM MODEM MODULE is a set of AT commands. AT commands are at the soul of the Modems, the GSM modem inclusive. It is important to note that there are general AT commands and proprietary commands are broad-specific. However, the software used to pre-configure the GSM Modem Module is the automated mode firmware before the introduction of the AT commands where the set of AT Commands used in the project to configure the GSM Modem Module as described in the Appendix A. To prevent SMS Message from the wrong source prompting an automated action, the SMS is validated against a username (AT#USR) and password. The SMS password string must be within double quotes and no greater than 20 characters long. Valid SMS message must contain the string binary at the start of the message to trigger a wakeup. To test the effectiveness of the GSM/GPRS Modem Module to perform the required operations, the value of <IO DATA> is entered in hexadecimal format and tested with some set of AT commands sent from the specified mobile phone numbers to trigger the I/O pins on the GSM/GPRS Modem Module and acknowledgement (message) was received immediately within seconds depends on the network traffic from the GSM/GRPS

Modem Module embedded inside the toy car to notify the owner that some certain operations have been initiated. However, it has been practically achieved and tested that the toy car was

immobilized and demobilized from the mobile phone via SMS, and also the warning alarm system inside the toy car was activated as well.

D. MOBILE STATION (Mobile Phone)

The Mobile station acts as a remote control device which grants the owner of the vehicle the access to the vehicle from any part of the world with GSM coverage. The SMS feature provided by GSM was employed by the design predefined to text messages from the mobile phone to the GSM modem. Since, it is an I/O device, it displays acknowledgements received from the GSM modem embedded inside the toy car. However, the major limitation about this work is a situation whereby there is lost of GSM network. It will be impossible to access vehicle subsystems via GSM at this time. Instead, two GSM phone numbers were configured on the GSM/GPRS

Modem Module in case, if there is network failure in one of the numbers, the other number can be used to initiate control actions on the vehicle from the mobile phone.

E. BASE STATION

This serves as an interface between the mobile phone and the GSM Modem Module. The base station is responsible for receiving data, at 9600 bps through the antenna of the GSM Modem Module which in turn decode the message on reception and performs the automated actions as indicated by the content of the message and the acknowledgement of reception is sent back to the mobile phone through the same coding and decoding process via the base station.

F. VEHICLE SUBSYSTEMS

This segment handles the various actions which the user wishes to perform once connection is established between the mobile station and the vehicle GSM/GPRS modem module.

The vehicle subsystem are as follows;

- Vehicle Demobilizer System
- Remote emergency warning system

G. VEHICLE DEMOBILIZER

This system automatically cuts off the battery supply to the ignition system of the toy car used. An I/O pin in the GSM/GPRS Modem Module is used to control this action. For the ignition system to perform the function of demobilization of the toy car, the normally closed relay connected between the positive terminal of the battery and the coil of the ignition becomes normally open upon reception of command lines from the mobile phone via the signal received by the modem module.

H. Remote Emergency Warning System

This system deals with the means by which the user keeps track of the status of the vehicle at every instance. In this system, the I/O line on the GSM/GPRS modem module is configured as an input pin and to accept emergency electrical when the vehicle ignition is turned on. The modem is configured to continuously monitor the status of the pin. Once an incoming electrical voltage is detected on the corresponding input, an originally configured sms message is sent to the pre-configured mobile phone numbers. This indicates that the vehicle is on. However, this system is expected to operate at any time the ignition is on. But in order to prevent frequent occurrence of this warning signal any time turned on, then the authorized user has to initiate some control actions on the system.

V. CONCLUSION

The major aim of this project was to design and construct a remotely controlled vehicle anti-theft system via GSM network. This can be accessed from a remote/distant location where there is GSM coverage and also monitor, control and initiate the vehicle demobilizer when the vehicle has been stolen. The GSM modem module for the remote communication was gotten from comtech holdings limited Bolton United Kingdom (UK). This GSM modem module incorporates on it, a micro-controlling unit which was programmed to control and monitor the vehicle subsystems. However, a toy car was used as a prototype display of this project work. The toy car was configured to send a warning message to the user on the press of the start button. Also, the prototype car was immobilized and demobilized from a mobile phone via SMS. Aside from the drawback of inconsistency in the availability of GSM network in the country, the project will be about a revolutionary improvement in the defense and security sector of the country.

REFERENCES

- [1] Aderibigbe, E.A. (2005). "Design and Construction of a home automation via domestic power line and GSM network" Unpublished B.Tech thesis, *Department of Electronic and Electrical Engineering, Ladoko Akintola University of Technology, Ogbomosho, Nigeria.*
- [2] Amusa, K.A., Nuga, O.O. & Adetomi, A.A. "Design of sms enabled Car Security System" Federal University of Agriculture, Abeokuta, *Transnational Journal of Science and Technology, November 2012 edition vol.2, No.10.*
- [3] JS (2004) Uweblite Design Manual. *Bolton United Kingdom (UK).*
- [4] Comtech Holding Ltd (2005). Uweblite Design Manual GSM/GPRS Getting Started Guide. *Bolton United Kingdom (UK).*
- [5] Comtech Holding Ltd (2004). UWeb/UWeBox Lite GSM/GPRS AT Commands manual guide. *Bolton United Kingdom (UK).*
- [6] Comtech Holding Ltd (2006) UwebLite Design Manual. *Bolton United Kingdom (UK).*
- [7] Freepatentsonline (2004-2007). Retrieved July, 2007 from 2004. *Bolton United Kingdom (UK).*
- [8] Han, H.P. & Tun, H.M. "Advanced Car Security System Using GSM", *International Journal of Scientific and Research Publications, Volume 4, Issue 5, May 2014. ISSN 2250-3153*
- [9] Ibrahim, V.M. & Victor, A.A. "Microcontroller Based Anti-theft Security System Using GSM Networks with Text Message as Feedback", *International Journal of Engineering Research and Development, Volume 2, Issue 10 (August 2012), PP. 18-22 Scalable Architecture for Sharing Online Experiments" International Conference on Engineering Education, ICEE. Gainseville, Florida.*
- [10] Jayendra1, G., Kumarawadu, S., & Meegahapola, L. "RFID-Based Antitheft Auto Security System with an Immobilizer", *Second International Conference on Industrial and Information Systems, ICIIS 2007, 8 11 August 2007, Sri Lanka.*
- [11] Karl, K., Czeskis, A., Roesner, F., Patel, S., & Kohno, T. "Experimental Security Analysis of a Modern Automobile", *Appears in 2010 IEEE Symposium on Security and Privacy. http://www.autosec.org/*
- [12] Kiruthiga, N., & Latha, L. "A Study of Biometric Approach for Vehicle Security System Using Fingerprint Recognition", *International Journal of Advanced Research Trends in Engineering and Technology (IJARTET) Vol. 1, Issue 2, October 2014.*
- [13] Kumar, C.N., Raghu Babu, Y.V., Gamyra, A., Jainath, P., & Vijay, M. "Design and Development of Activation and Controlling Of Home Automation System VIA SMS through Microcontroller", *International Journal of Engineering Research and Applications (IJERA) ISSN: 2248-9622 www.ijera.com Vol. 2, Issue 2, Mar-Apr 2012, pp.1349-1352.*
- [14] Muhammad, T.Q., Syed, S.Q., Rafia, K., & Khan, M.Y. "Automated Profile Vehicle Using GSM Modem, GPS and Media Processor DM642" Department of Electronic Engineering, Sir Syed University

of Engineering & Technology, Karachi, Pakistan, 2009 *International Conference on Computer Engineering and Applications IPCSIT vol.2 (2011) (2011) IACSIT Press, Singapore.*

[15] Montaser, N.R., & Mohammad, A.A. "Senior Member", IACSIT, A.A Sharaf, "Intelligent Anti-Theft and Tracking System for Automobiles" *International Journal of Machine Learning and Computing, Vol. 2, No. 1, February 2012.*

[16] National Motor Vehicle Theft Reduction Council (2007).

[17] Omprakash, K.S. "WIRELESS HOME SECURITY SYSTEM WITH MOBILE" *International Journal of Advanced Engineering Technology, E-ISSN 0976-3945.*

[18] Pang-Chieh, W., Ting-Wei, H., Jung-Hsuan, W., & Bo-Chiuan, C. "A Security Module for Car Appliances" *World Academy of Science, Engineering and Technology Vol:1 2007-11-28 . International Science Index Vol:1, No:11, 2007 waset.org/Publication/11397.*

[19] Patil, S.V., & Sardeshmukh, M.M. "Face Recognition by Weber Law Descriptor for Anti-Theft Smart Car Security System." *International Journal of Emerging Technology and Advanced Engineering, Volume 4, Issue 5, May 2014.*

[20] Powale, P.K., & Zade, G.N. "Real time Car Antitheft System with Accident Detection using AVR Microcontroller; A Review" *International Journal of Advance Research in Computer Science and Management Studies, Volume 2, Issue 1, January 2014, ISSN: 2321-7782 (Online).*

[21] Rohitaksha, K., Madhu, C.G., Nalini, B.G., & Nirupama, C.V. "Android Application for Vehicle Theft Prevention and Tracking System" *International Journal of Computer Science and Information Technologies, Vol. 5 (3), 2014, 3754-3758*

[22] Sheikh, I.A., & Sushil, K. "Analysis and Performance of a Low Cost SMS Based Home Security System" School of Engineering and Physics, The University of the South Pacific *International Journal of Smart Home Vol. 5, No. 3, July, 2011.*

[23] Sot, S. "MMS Based Car Security System" *International Journal of Electronics and Computer Science Engineering. ISSN- 2277-1956.*

APPENDIX

A. Extended AT command Description for Automated Mode of Operation of the GSM Modem.

TABLE III
AT#MO AUTOMATED MODE OF OPERATION

Description	Commands	Possible Responses
Set the mode of operation	AT#MO=<MODE>	ERROR or OK
Read the current setting	AT#MO?	<MODE>

TABLE IV
AT#WAK WAKEUP SOURCE

Description	Commands	Possible Responses
Set wake source	AT#WAK=<WAKEUP>	ERROR or OK
Read wakeup source	AT	

TABLE V
AT#PWD SMS PASSWORD

Description	Commands	Possible Responses
Set the sms password	AT#PWD=<PASSWORD>	ERROR or OK
Read wakeup source	AT#PWD?	<PASSWORD>